

METRACLIP[®] 61

Clip-On Ammeter

3-349-173-37
1/9.01

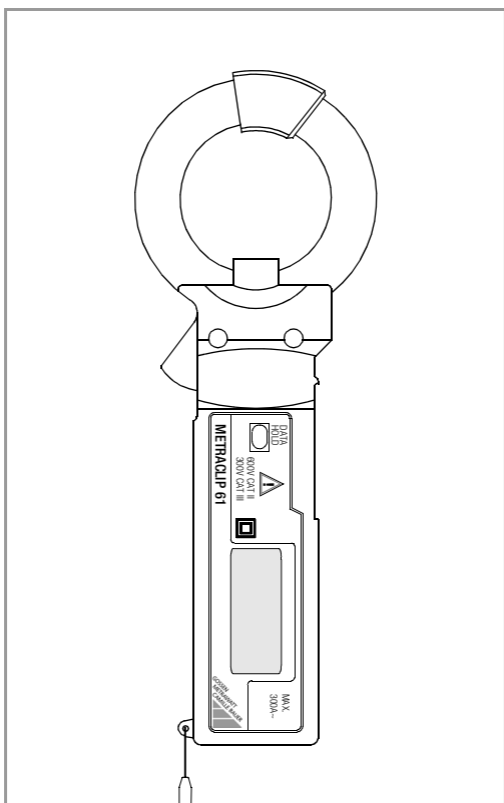

GOSSEN-METRAWATT GMBH
Thomas-Mann-Str. 16-20
90471 Nürnberg, Germany
Phone: +49 911 8602-0
Fax: +49 911 8602-669
e-mail: info@gmc-instruments.com
<http://www.gmc-instruments.com>

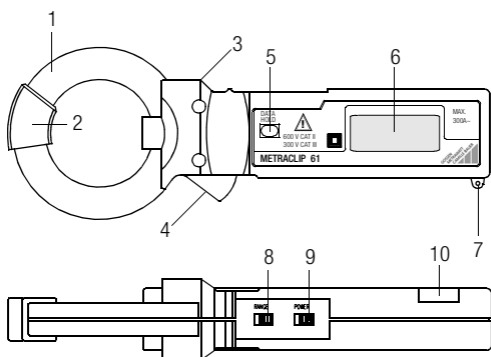

- 1 Clip jaw
- 2 Clip guide
- 3 Clip clearance safety barrier:
Do not reach beyond the safety collar!
- 4 Button for opening clip
- 5 DATA HOLD key: saves measured value
- 6 Display (LCD)
- 7 Eyelet for carrying strap
- 8 Measuring range switch (RANGE)
- 9 On/off switch (POWER)
- 10 Battery compartment lid (secured with Phillips head screw)

Table of Contents	Page
1 Safety Precautions	3
2 Operation	4
2.1 Initial Start-Up	4
2.2 Stipulations for All Measurements	4
2.3 Measuring Leakage Current at Grounded Conductors	4
2.4 Measuring Leakage Current at Single-Phase or 3-Phase Systems	5
2.5 Measuring Line Current	5
3 Characteristic Values	6
4 Maintenance	7
4.1 Battery Replacement	7
4.2 Housing	7
5 Repair and Replacement Parts Service DKD Calibration Lab and Rental Instrument Service	8
6 Product Support	8

1 Safety Precautions

The METRACLIP® 61 clip-on ammeter has been manufactured and tested in accordance with safety regulations IEC 61010-1/EN 61010-1/VDE 0411-1 and IEC 61010-2-032/EN 61010-2-032/VDE 0411-2-032. If used for its intended purpose, safety of the user and of the device is assured. The device may only be operated by properly trained personnel who are capable of recognizing the dangers associated with the measurement of electrical current and voltage.

Read the operating instructions completely and carefully before using the device, and follow all instructions included therein.

Meanings of symbols on the instrument:



Warning concerning a source of danger
(Attention: observe documentation!)



Continuous, doubled or reinforced insulation



Indicates EC conformity

CAT II Maximum allowable voltage at the circuit under test: 600 V, category II

The clip-on ammeter may not be used:

- If the battery compartment lid has been removed
- If visible damage is apparent
- With damaged connector cables
- If it no longer functions flawlessly
- After lengthy periods of storage under unfavorable conditions (e.g. humidity, dust, temperature)



Attention!

Do not perform measurements in the event of over-ranging!

Current which exceeds the measuring range may not be measured.

Do not perform measurements at bare wires!

Do not perform measurements at busbars!

Safe Handling

- The housing and the handle must be free of dust, grease and moisture.
- The operator's fingers may not be extended beyond the safety collar during measurement.
- Avoid excessive mechanical stress such as impact and vibration, as well as high temperatures and strong magnetic fields.
- The battery compartment lid must be secured with the appropriate Phillips head screw.

2 Operation

2.1 Initial Start-Up

Insert the two button cell batteries (see chapter 4.1 on page 7).

2.2 Stipulations for All Measurements



Attention!

Line voltage at the AC circuit to be under test may not exceed a value of **600 V AC**.

Current may only be measured at values of **up to 300 A**.

DATA HOLD Function

During the performance of measurements under conditions which impair easy reading of display values, the DATA HOLD key can be activated in order to freeze the momentary measured value at the display. The **DH** symbol appears at the display and is highlighted.

Before starting any new measurements, the DATA HOLD key must be activated once again in order to reset the data hold function.

2.3 Measuring Leakage Current at Grounded Conductors

- Turn the measuring instrument on with the on/off switch (POWER switch to ON position).
- Set the measuring range switch (RANGE) to the appropriate range for the current to be measured. Otherwise, set the measuring range switch to the higher range in order to avoid possible over-ranging.
- Close the clip around the current conducting cable under test.
- Read the measured value from the display.
- After measurement has been completed:
Remove the clip from the cable and set the on/off switch (POWER) to the OFF position.

2.4 Measuring Leakage Current at Single-Phase or 3-Phase Systems

- Turn the measuring instrument on with the on/off switch (POWER switch to ON position).
- Set the measuring range switch (RANGE) to the appropriate range for the current to be measured. Otherwise, set the measuring range switch to the higher range in order to avoid possible over-ranging.
- **Single-phase systems:**
Close the clip around both conductors.
- **3-phase systems:**
Close the clip around all three conductors.
- Read the measured value from the display.
- After measurement has been completed:
Remove the clip from the cable and set the on/off switch (POWER) to the OFF position.

2.5 Measuring Line Current

- Turn the measuring instrument on with the on/off switch (POWER switch to ON position).
- Set the measuring range switch (RANGE) to the appropriate range for the current to be measured. Otherwise, set the measuring range switch to the higher range in order to avoid possible over-ranging.
- Close the clip around a single current conducting cable.
- Read the measured value from the display.
- After measurement has been completed:
Remove the clip from the cable and set the on/off switch (POWER) to the OFF position.

3 Characteristic Values

Alternating Current: mA AC / A AC (manually selectable)

Measuring Range	Range of Use	Resolution	Accuracy
0 ... 30 mA 0 ... 300 mA	0 ... 300 mA	0.01 mA	±1.2% rdg. ±5 digits
0 ... 30.00 A 0 ... 300.0 A	0 ... 200 A	0.01 A	±1.2% rdg. ±5 digits
	200 ... 250 A		-3% rdg. ±5 digits
	250 ... 300 A		-5% rdg. ±5 digits

Frequency Range 50 ... 60 Hz

Reference Conditions

Ambient temperature +23 °C ±5 °C
Relative humidity max. 80%

LCD

Display 7-segment characters and bargraph
Number of places 3½ digits, max. display: 3200
Sampling rate Digital display: 2 per second
Bargraph: 12 per second
Overflow display **OL** appears
DATA HOLD display **DH** appears

Power Supply

Batteries 2 ea. LR44 or SR44
Service life With LR44 (alkaline manganese): roughly 50 hours (approx. 5 mW)
Battery test **+** is displayed automatically if battery voltage drops to below approx. 2.7 V.
Automatic shutdown The device turns itself off automatically 10 minutes after it has been switched on.

Electrical Safety

Safety class II per IEC 61010-1
Overvoltage category CAT II 600 V
CAT III 300 V
Dielectric strength 3.7 kV AC, max. 1 minute, between cable core and clip
Maximum voltage at the circuit under test < 600 V AC

Electromagnetic Compatibility (EMC)

Interference emission IEC 61236-1
Interference immunity IEC 61236/A1

Ambient Conditions

Operating temperature 0 °C ... +40 °C
Storage temperature -10 °C ... +60 °C (without batteries)
Relative humidity max. 80%, no condensation allowed
Elevation to 2000 m

Mechanical Design

Protection	IP 40
Clip opening	max. 40 mm diameter
Dimensions	W x H x D: 64 mm x 176 mm x 23 mm
Weight	approx. 125 gr. with batteries

4 Maintenance

4.1 Battery Replacement

If the BAT symbol appears at the display, the button cell batteries are either depleted or no longer supply sufficient operating voltage, and must be replaced. The batteries should also be removed if the instrument is placed into storage for a lengthy period of time, because leakage might otherwise occur.



Attention!

Remove the clip from the circuit under test first. Only then may the battery compartment lid be removed in order to replace the batteries.

-
- Set the on/off switch (POWER) to the **OFF** position.
 - Remove the screw (size 0) which is used to secure the battery compartment lid.
 - Pry up the battery compartment lid at the side secured with the screw until noticeable resistance is discerned (corresponds to an angle of approx. 45°). Pull the lid to the right and remove.
 - Carefully pry the batteries out of the compartment with the Phillips head screwdriver.
Replace the depleted batteries. Make sure the batteries are inserted with correct polarity (plus pole at the top).



Note!

Always replace both batteries at once.

-
- Set the battery compartment lid back into place with the left side flush to the housing at an angle of approximately 45°.
Close the lid. The lid must audibly snap into place, and must be flush with the surface of housing all the way around its perimeter.
 - Reinsert and tighten the screw.



Note!

The measuring instrument does not include any replaceable fuses!

4.2 Housing

No special maintenance is required for the housing. Keep outside surfaces clean. Use a slightly dampened cloth for cleaning. Avoid the use of cleansers, abrasives and solvents.

5 Repair and Replacement Parts Service DKD Calibration Lab and Rental Instrument Service

When you need service, please contact:

GOSSEN-METRAWATT GMBH
Service-Center
Thomas-Mann-Strasse 20
90471 Nürnberg, Germany
Phone +49 911 86 02 - 410 / 256
Fax +49 911 86 02 - 2 53
e-mail fr1.info@gmc-instruments.com

This address is only valid in Germany.
Please contact our representatives or subsidiaries for
service in other countries.

6 Product Support

When you need support, please contact:

GOSSEN-METRAWATT GMBH
Product Support Hotline
Phone +49 911 86 02 - 112
Fax +49 911 86 02 - 709
e-mail vmp.info@gmc-instruments.com